



14+



8



2m



1 = 7,13m
2 = 1,46m
3 = 2,32m



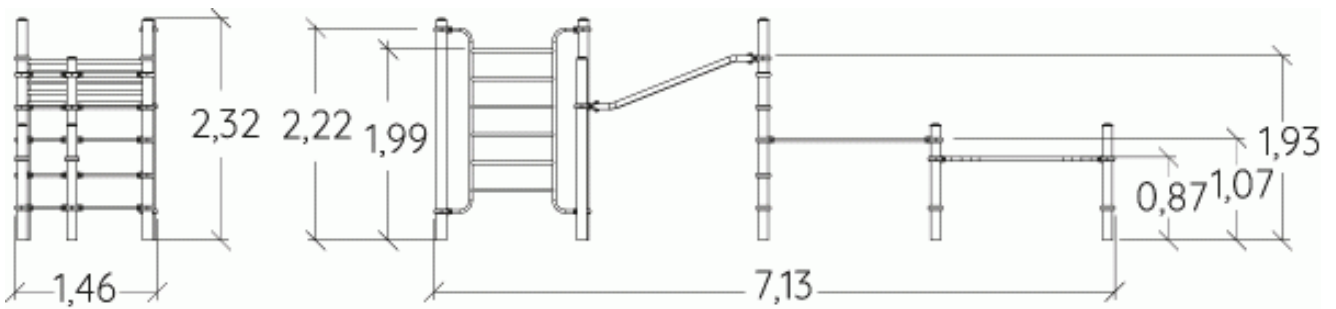
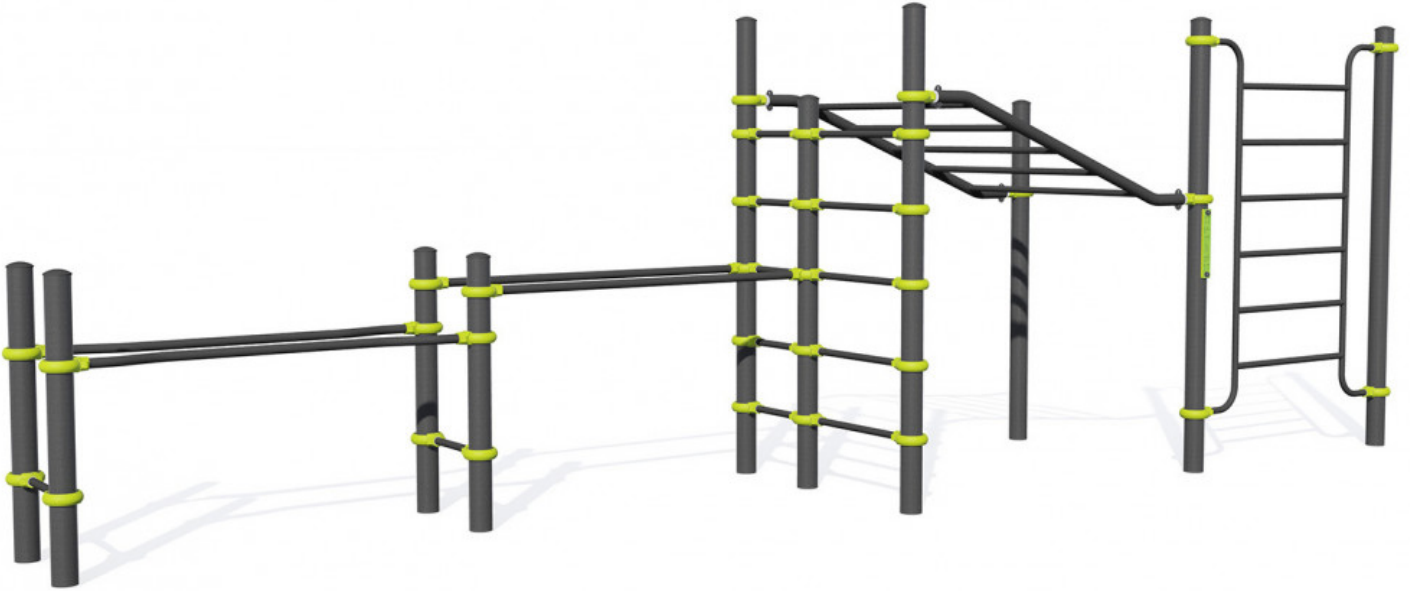
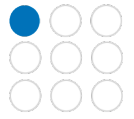

Motor inclusion
Sensory inclusion
Mental inclusion



Installation of equipment

IMPORTANT: It is essential to refer to the installation instructions for information on the size of the safety areas.

-  Impact area (minimum normative surface)
-  Free space

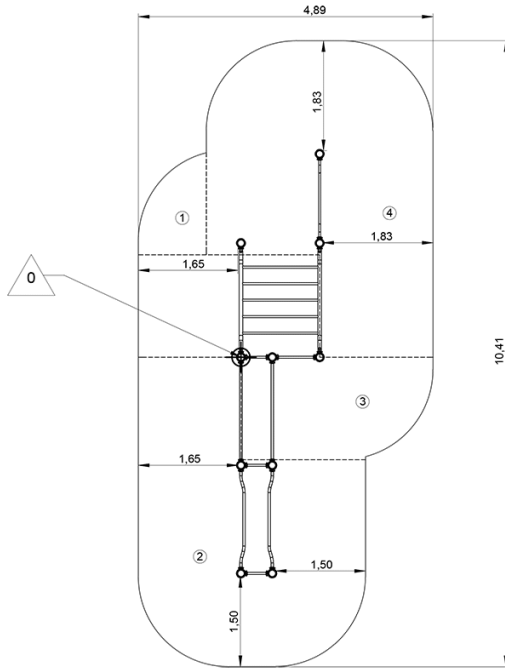

1	0,9m	1,5m ²
2	1,1m	15m ²
3	1,7m	10m ²
4	2m	16m ²



3



07h00



1.5m³



42.5m²



282kg



22kg

